

Electrical connection

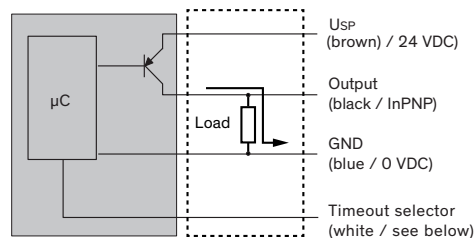

Time-out function

- ▶ Connect white wire to 24 VDC to implement 18 s / 7 s timeout (i.e. sensor enters a 7 s sleep mode after 18 s of the first detection, see Installation and Operation Manual); or
- ▶ Connect white wire to 0 VDC for no timeout function.

Technical data

Optical

Detection height	0.6 ... 2.5 m (2 ... 8.1 ft)
Detection area at 2 m (6.5 ft)	200 mm x 900 mm (7.9 in x 35.5 in)
Min. object detection at 2 m (6.56 ft)	40 mm (1.57 in)

Mechanical

Dimensions (l x h x w)	132 x 36 x 34 mm (5.2 x 1.42 x 1.34 in)
Housing material	Aluminum, PC
Enclosure rating	IP65
Temperature range	-20 °C ... +60 °C (- 4 °F ... +140 °F)

Electrical

Supply voltage UsP	24 VDC ±20%
Max. / typ. current consumption at 24 VDC	500 mA / 200 mA
Output	PNP
Max. output load	120 mA, 100 nF
Output logic	LOW Object HIGH No object
Response time	350 ms
Max. recalibration time	1.5 s

Output logic

Output	UsP	0 V	Object detected	Door mode
Status	No object	Object detected	Door mode	
Output	24 VDC HIGH	0 VDC LOW	24 VDC HIGH	
Red LED	OFF	ON	Blinking	

Important:

- ▶ Remove the foil from the optical cover after the electrical connection but before testing.
- ▶ Make sure that the power supply voltage available for the IMS 100 Pro is +24 VDC ±20%.

Connection cable and electrical connection

Sensor cable	
- Length	0.5 m (19.5 in)
- Diameter	Ø 3.5 mm (0.14 in)
- Connector to connection cable (blue)	M8, 4-pin, Ø 10 mm (0.39 in)

Connection cable	
- Length	2.8 m (9 ft)
- Diameter	Ø 3.5 mm (0.14 in)
- Connector to sensor (black)	M12, Ø 14 mm (0.55 in)
Cable material	PVC, black

Ferrite Core	Diameter	Ø 16 mm (0.63 in)
	Length	42 mm (1.65 in)
Wires	AWG26	

• brown	UsP
• blue	GND (0 V)
• black	Output (PNP)
• white	Time-out selector (18 s / 7 s or infinity [off])

General

Eye safety	IEC 60825-1
EMC emission	EN 12015:2014
EMC immunity	EN 12016:2013
Vibration	IEC 60068-2-6:2007
Shock	IEC 60068-2-27:2008
RoHS	2011/65/EU
Certificates	CE, CSA

CEDES AG reserves the right to modify or change technical data without prior notice.
For the complete IMS 100 Pro Installation and Operation Manual, please visit www.cedes.com



Overview

Flush mounting

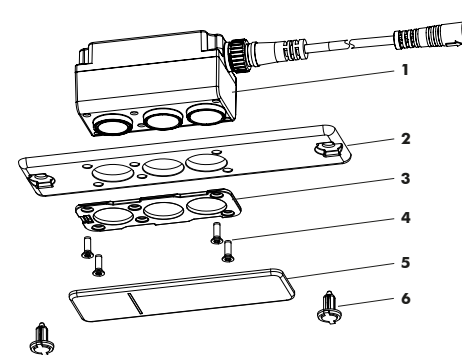

Surface mounting

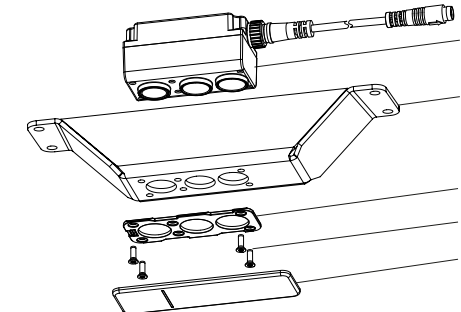

1	2	3	4	5	6	7
Sensor	Mounting bracket	Fixing plate	Screws	Optical cover	Expanding rivets	Stainless steel housing

Note: Ferrite on sensor cable not displayed

Hazards of laser radiation

The IMS 100 Pro is a Laser Class 1 device and fulfills eye safety requirements when used as described in this document and the IMS 100 Pro operating instructions (i.e. under normal operating conditions).



DANGER - INVISIBLE LASER RADIATION CLASS 4

If, however, the sensor becomes damaged, particularly regarding the emitting lenses associated with the laser(s) or exposure of the internal electronics, the device can reach Laser Class 4 levels and eyes or skin could become damaged due to a much higher level of exposure to direct or scattered laser radiation. This must always be avoided!

If the sensor is damaged (e.g. damage to the emitting lenses on the sensor, or the housing integrity is compromised and exposes the internal electronics), switch the power supply off immediately and replace the sensor!

NOTICE:

- Any alterations to the device may result in unsafe operating conditions. CEDES is not responsible for any liability or warranty claim that results from such manipulation.

Safety instructions

- ▶ Switch off main power to the elevator control system and mark clearly that the elevator is out of service.
- ▶ Follow all applicable safety measures.
- ▶ Make sure that your installation complies with all applicable standards, laws and regulations that apply to your application. It is the sole responsibility of the planner and/or installer and/or buyer.
- ▶ The IMS 100 Pro should only be installed by authorized and fully trained personnel! The installer or system integrator is fully responsible for the safe integration of the sensor.
- ▶ The IMS 100 Pro **must not** be used for: Protection of dangerous machinery, equipment in explosive atmospheres nor in radioactive environments.
- ▶ Never scratch or paint the optical cover.
- ▶ Never use any solvents, cleaners or mechanically abrasive towels or high-pressure water to clean the sensor. Avoid scratching the optical covers while cleaning.

Important:

This product cannot fulfill ANSI-ASME A17.1-2019 / CSA B44-19 safety code for elevators and escalators or later versions due to the new requirements of the code. Contact your local CEDES representative if you need assistance with product selection to fulfill the requirements of this version of the code.

Installation

Overview

Important:
When mounting, ensure the cable always exits right - when viewed facing into the elevator cabin.

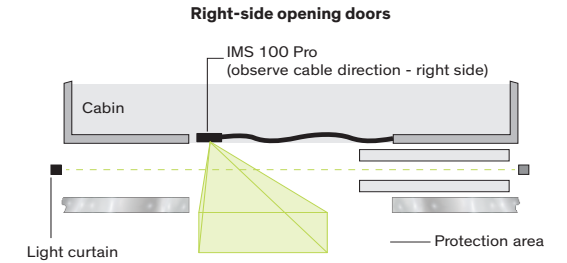
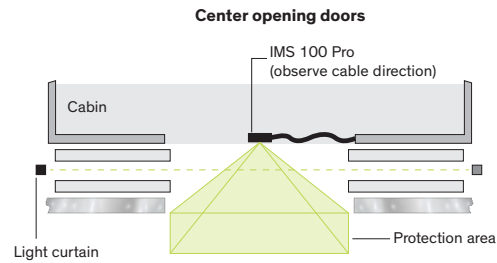
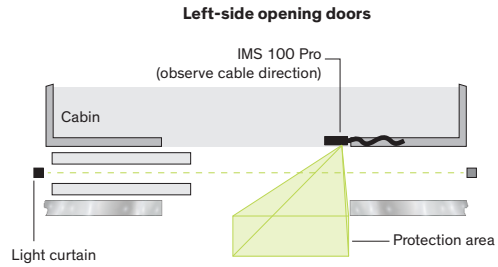

Mounting steps

- 1 Stainless steel housing
- 2 Screws
- 3 Assembled sensor
- 4 Expanding rivets
- 5 Bushing

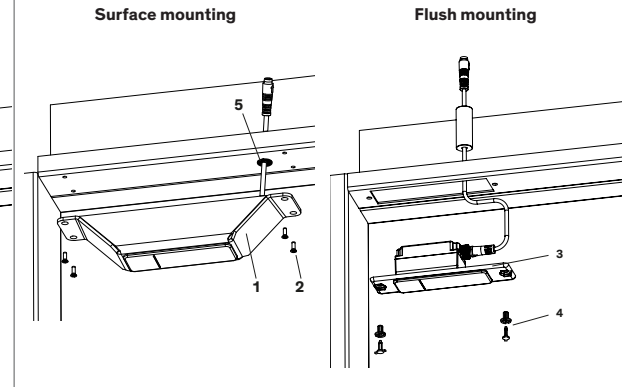
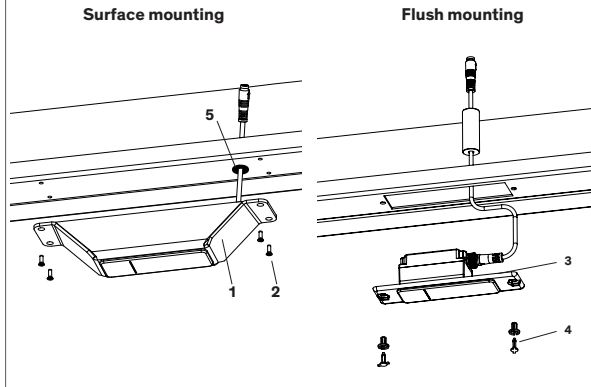
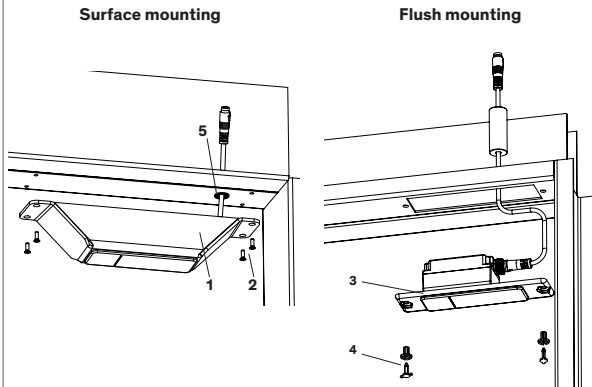

Drilling and cutout instructions

Notice (left-/right-side):
The further away the IMS 100 Pro is mounted from the door frame, the earlier the sensor switches into the door mode (door has been detected) and no longer detects objects.

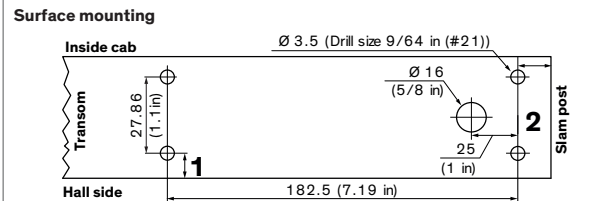

▶ For the sensor cable, drill a 16 mm (5/8 in) hole, located inside the four mounting holes, but on the right hand side. Snap in bushing. Position (stainless steel housing) to the hall side (1): ≥ 7 mm ≤ 90 mm (≥ 0.28 in ≤ 3.54 in); min. distance (drilling hole) to the slam post (2): ≥ 7 mm (≥ 0.28 in)

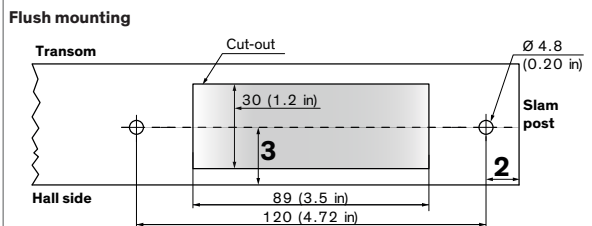

▶ Cutout position to the hall side (3): ≥ 18 mm ≤ 100 mm (≥ 0.7 in ≤ 3.93 in); max. distance of the cutout to the drilling hole: 16 mm (5/8 in); min. distance (drilling hole) to the slam post (2): ≥ 7 mm (≥ 0.28 in)

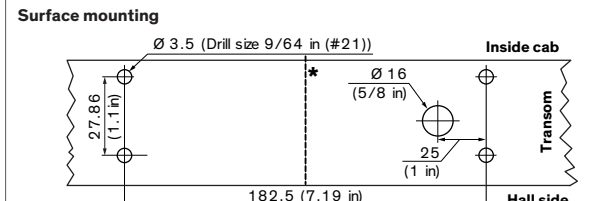

▶ For the sensor cable, drill a 16 mm (5/8 in) hole, located inside the four mounting holes, but on the right hand side. Snap in bushing. Position (stainless steel housing) to the hall side (1): ≥ 7 mm ≤ 90 mm (≥ 0.28 in ≤ 3.54 in)

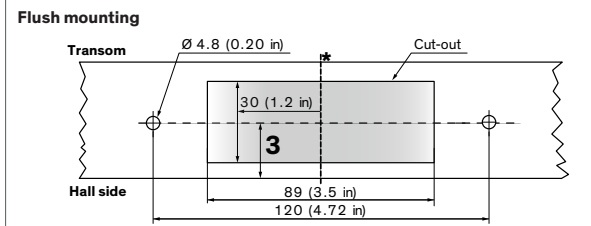

▶ Cutout position to the hall side (3): ≥ 18 mm ≤ 100 mm (≥ 0.7 in ≤ 3.93 in)

Important for correct mounting: This center line* is the center of the door.

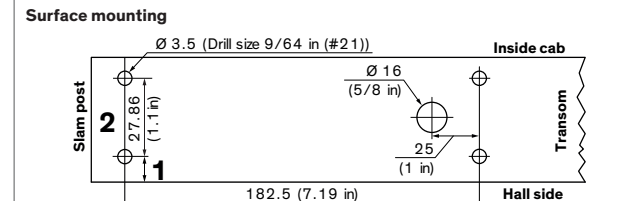

▶ For the sensor cable, drill a 16 mm (5/8 in) hole, located inside the four mounting holes, but on the right hand side. Snap in bushing. Position (stainless steel housing) to the hall side (1): ≥ 7 mm ≤ 90 mm (≥ 0.28 in ≤ 3.54 in); min. distance (drilling hole) to the slam post (2): ≥ 27 mm (≥ 1.06 in)

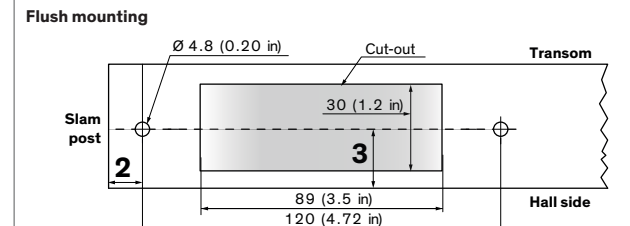

▶ Cutout position to the hall side (3): ≥ 18 mm ≤ 100 mm (≥ 0.7 in ≤ 3.93 in); max. distance of the cutout to the drilling hole: 16 mm (5/8 in); min. distance (drilling hole) to the slam post (2): ≥ 67 mm (≥ 2.63 in)